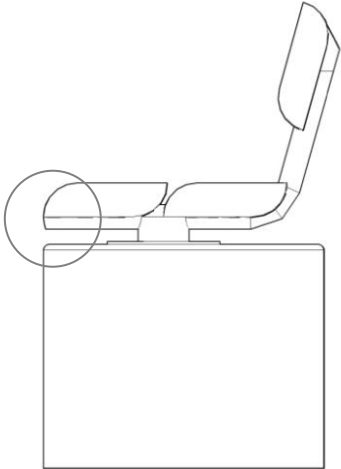
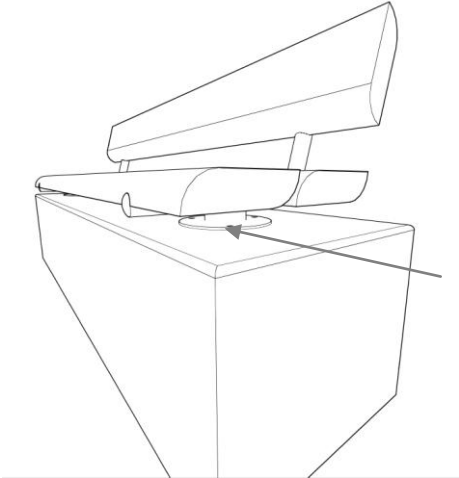
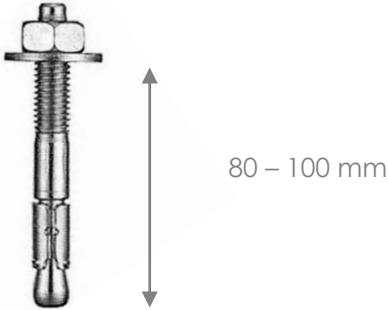

Installation Guidelines – Wall Mounted Basic Bench (Existing Plinth)

These instructions are intended as guidelines only. Citysquared recommend employing experienced professionals for any installation.

<p>1.0</p> <p>The bench is fitted using anchor bolts to attach to the plinth beneath. Benches are delivered with the Stainless Steel legs already attached. In most cases, Citysquared would recommend that the front of the bench runs flush with the front of the plinth.</p> 	<p>2.0</p> <p>Position the bench lengthwise along the plinth as desired. Then, using a suitable pen/pencil, mark through the fixing points to the surface of the plinth. There are 4no fixing points on each leg.</p> <p>Remove the bench.</p> 
<p>3.0</p> <p>Using an appropriate SDS drill and drill bit to suit the anchor bolt being used, drill into the hard surface to the appropriate depth. M10 Stainless Steel Anchor Bolt (through-bolt type) is recommended. Please note; fixing hole in leg plate is 16mm diameter.</p> 	<p>4.0</p> <p>Lightly tap the anchor bolt into the hole. Place the bench back over the drilled holes. Using an appropriate size socket wrench or ratchet spanner, tighten the bolt, tap again and tighten until secure. A polyester resin can be used if required (e.g. Fischer FIS P380C).</p> 